

HRTL 55 Laser diffuse reflection light scanner with background suppression

en 01-2011/02 50110334



10 ... 400mm
170mm with
black-white error < 10%

10 - 30 V
DC

2 kHz

A²LS

stainless steel
316 L

- Laser diffuse reflection light scanner with visible red light and adjustable background suppression
- 316L stainless steel housing in WASH-DOWN-Design
- Enclosed optics design prevents bacterial carry-overs
- ECOLAB and CleanProof+ tested
- Paperless device identification
- Plastic front cover
- Exact scanning range adjustment through 8-turn potentiometer
- Collimated light beam propagation with small beam diameter permits identical switching behavior within the specified scanning range

Dimensioned drawing

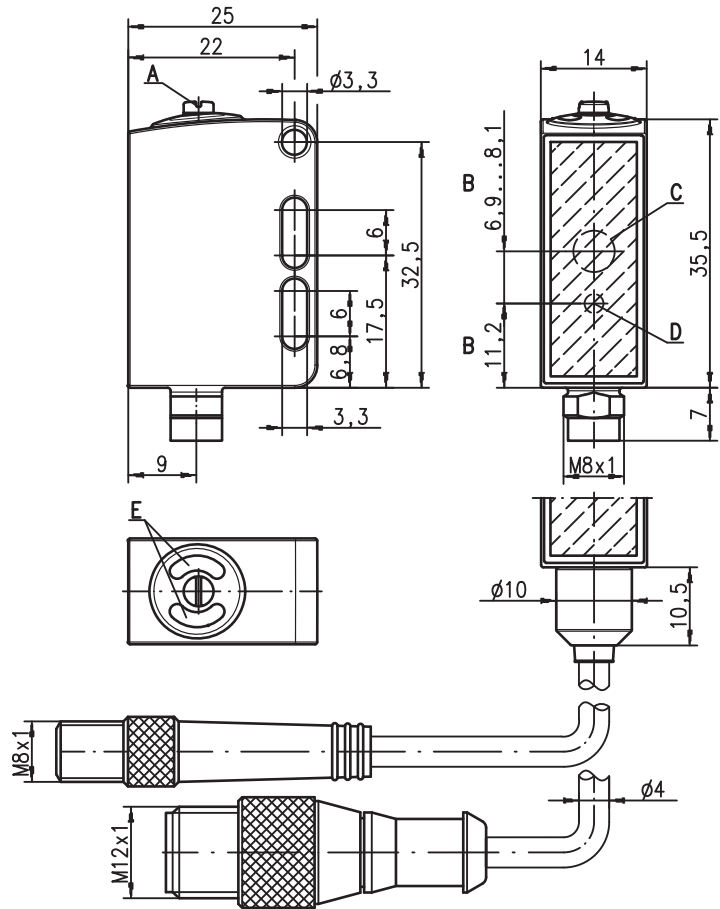

- A** 8-turn potentiometer for scanning range adjustment
- B** Optical axis
- C** Receiver
- D** Transmitter
- E** Indicator diode

Electrical connection

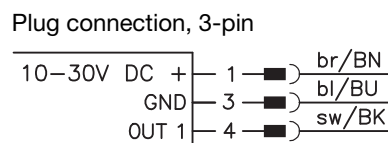
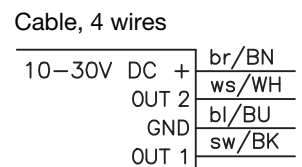
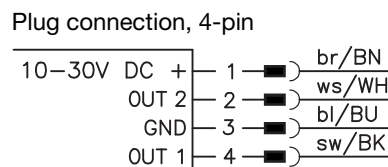

We reserve the right to make changes • DS_HRTL55_en.fm

CE, UL LISTED, ECOLAB CleanProof+, CDRH, IEC 60947..., IEC 60947..., IP 69K IP 67, WASH DOWN

Accessories:

- (available separately)
- Cable with M8 or M12 connector (K-D ...)
 - Cable for food and beverages
 - Mounting devices

Specifications

Optical data

Typ. scanning range limit ¹⁾
 Scanning range ²⁾
 Adjustment range of the switching point
 Black/white error < 10% up to
 Light beam diameter
 Light beam characteristic
 Squint angle
 Light source ³⁾
 Wavelength
 Max. output power
 Pulse duration

Laser class 1

10 ... 400mm
 see tables
 20 ... 400mm
 170mm
 approx. 1 mm, consistent
 collimated
 typ. ± 2°
 laser, pulsed
 650nm (visible red light)
 < 0.81mW
 7µs

Timing

Switching frequency
 Response time
 Response jitter
 Decay time
 Delay before start-up

2,000Hz
 0.25ms
 typ. 65µs
 0.25ms
 ≤ 300ms

Electrical data

Operating voltage U_B ⁴⁾
 Residual ripple
 Open-circuit current
 Switching output

10 ... 30VDC (incl. residual ripple)
 ≤ 15% of U_B
 ≤ 20mA
 2 push-pull switching outputs
 pin 2: PNP dark switching, NPN light switching
 pin 4: PNP light switching, NPN dark switching
 1 push-pull switching output
 pin 4: PNP light switching, NPN dark switching
 ≥ ($U_B - 2V$) / ≤ 2V
 max. 100mA
 adjustable via 8-turn potentiometer

Signal voltage high/low
 Output current
 Scanning range

.../66⁵⁾
 .../6⁵⁾

Indicators

Green LED
 Yellow LED

ready
 object detected - reflection

Mechanical data

Housing
 Housing design
 Housing roughness ⁶⁾
 Connector
 Optics cover
 Operation
 Weight

AISI 316L stainless steel, DIN X2CrNiMo17132, W.No1.4404
 WASH-DOWN-Design
 $R_a \leq 2.5$
 AISI 316L stainless steel, DIN X2CrNiMo17132, W.No1.4404
 plastic (PMMA)
 plastic (TPV - PE), non-diffusive
 with M8 connector: 40g
 with 200mm cable and M12 connector: 60g
 with 5000mm cable: 110g
 M8 connector, 4-pin,
 0.2m cable with M12 connector, 4-pin,
 5m cable, 4 x 0.20mm²

Connection type

Environmental data

Ambient temp. (operation/storage) ⁷⁾
 Protective circuit ⁸⁾
 VDE safety class
 Protection class
 Environmentally tested acc. to
 Laser class

-30°C ... +70°C / -30°C ... +70°C
 2, 3
 III
 IP 67, IP 69K⁹⁾
 ECOLAB, CleanProof+
 1 (according to EN 60825-1 and 21 CFR 1040.10
 with Laser Notice No. 50)

Standards applied
 Certifications
 Chemical resistance

IEC 60947-5-2
 UL 508 ⁴⁾
 tested in accordance with ECOLAB and CleanProof+
 (see Remarks)

- 1) Typ. scan. range limit/adjustment range: max. achievable scanning range/adjustment range for light objects (white 90%)
- 2) Scanning range: recommended scanning range for objects with different diffuse reflection
- 3) Average life expectancy 50,000h at an ambient temperature of 25°C
- 4) For UL applications: for use in class 2 circuits according to NEC only
- 5) The push-pull switching outputs must not be connected in parallel
- 6) Typical value for the stainless steel housing
- 7) Operating temperatures of +70°C permissible only briefly (≤ 15min)
- 8) 2=polarity reversal protection, 3=short-circuit protection for all transistor outputs
- 9) Only in combination with M12 connector

Tables

Models of laser class 1:

1	15	400
2	15	250
3	15	170

1	white 90%
2	gray 18%
3	black 6%

□ Scanning range [mm]

Diagrams

Models of laser class 1:

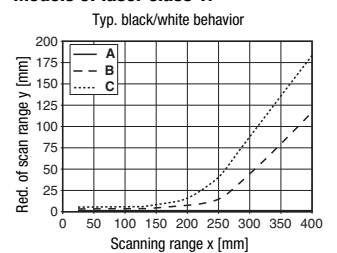

- A white 90%
- B gray 18%
- C black 6%

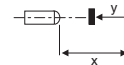

Remarks

A list of tested chemicals can be found in the first part of the product description.

HRTL 55 Laser diffuse reflection light scanner with background suppression

Part number code

H R T L 5 3 / 6 6 . C 2 , 2 0 0 - S 1 2

Operating principle

HRT Diffuse reflection light scanners with background suppression

Operating principle

L Laser (red light)

Construction/version

53 53 Series

55 55 Series

Switching output/function (OUT 1: pin 4, OUT 2: pin 2)

/66 2 x push-pull transistor output, OUT 1: light switching, OUT 2: dark switching

/6 1 x push-pull transistor output, OUT 1: light switching, OUT 2: not connected (n. c.)

Equipment

N/A Laser class 1 in accordance with EN 60825-1

.C2 Laser class 2 in accordance with EN 60825-1

Electrical connection

N/A Cable, PVC, standard length 2000mm, 4-wire

-S8.3 M8 connector, 3 pin (plug)

-S8 M8 connector, 4 pin (plug)

,200-S12 Cable, PVC, length 200mm with M 12 connector, 4 pin, axial (plug)

,5000 Cable, PVC, standard length 5000mm, 4-wire

Order guide

The sensors listed here are preferred types; current information at www.leuze.com

Order code

Part No.

HRTL 55/66, 5000

50115205

HRTL 55/66-S8

50115206

HRTL 55/66, 200-S12

50115204

Application notes



- **Approved purpose:**
This product may only be used by qualified personnel and must only be used for the approved purpose. This sensor is not a safety sensor and is not to be used for the protection of persons.
- **Detection of glossy surfaces within the scanning range:**
When detecting glossy surfaces (e.g. metals), the light beam should not hit the object surface at a right angle. A slight inclination suffices to prevent undesirable direct reflections. The following rule of thumb applies: the smaller the scanning range, the larger the angle of the inclination (approx. $5^\circ \dots 7^\circ$).

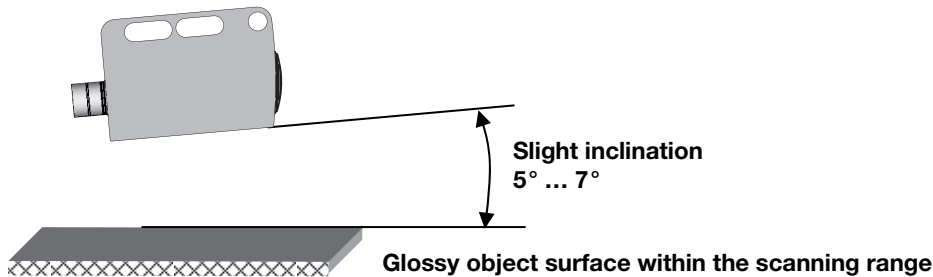

- **Avoiding interference from glossy surfaces in the background:**
If a glossy surface is in the background (distance larger than scanning range limit), reflections may cause interfering signals. These may be avoided by mounting the device at a slight angle (see figure below).



Attention!
It is imperative to note the task and the associated inclination of the scanner of approx. $5^\circ \dots 7^\circ$.

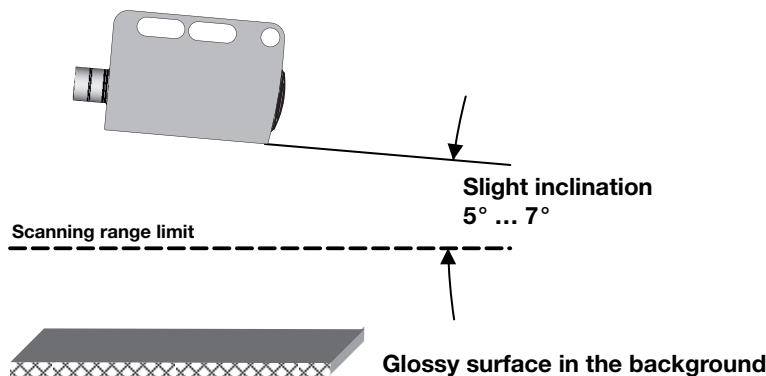

- Objects should only be moved in laterally from the right or left. Moving in objects from the connection side or operating side is to be avoided.
- Outside of the scanning range, the sensor operates as an energetic diffuse reflection light scanner. Light objects can still be reliably detected up to the scanning range limit.
- The sensors are equipped with effective measures for the maximum avoidance of mutual interference should they be mounted opposite one another. Opposite mounting of multiple sensors of the same type should, however, absolutely be avoided.

HRTL 55 Laser diffuse reflection light scanner with background suppression

Object detection behind diaphragms

It is sometimes necessary to mount the sensor behind plant parts so that the light beam has to pass through an opening (diaphragm) that is as small as possible. Here, the detection depends, among other things, on set scanning range t_w , distance a between diaphragm and sensor, and diaphragm diameter d . Here are some reference values ¹⁾:

Distance a [mm] between sensor and diaphragm	Diaphragm diameter d [mm], dependent on scanning range t_w [mm] on a white object (90% diffuse reflection) set on the sensor		
	$t_w = 100$	$t_w = 200$	$t_w = 300$
10	10	10	10
30	8	8	9
50	7	8	9
80	6	7	8
100	6	6	8
120		6	8
150		5	6
180		5	6
200		5	6

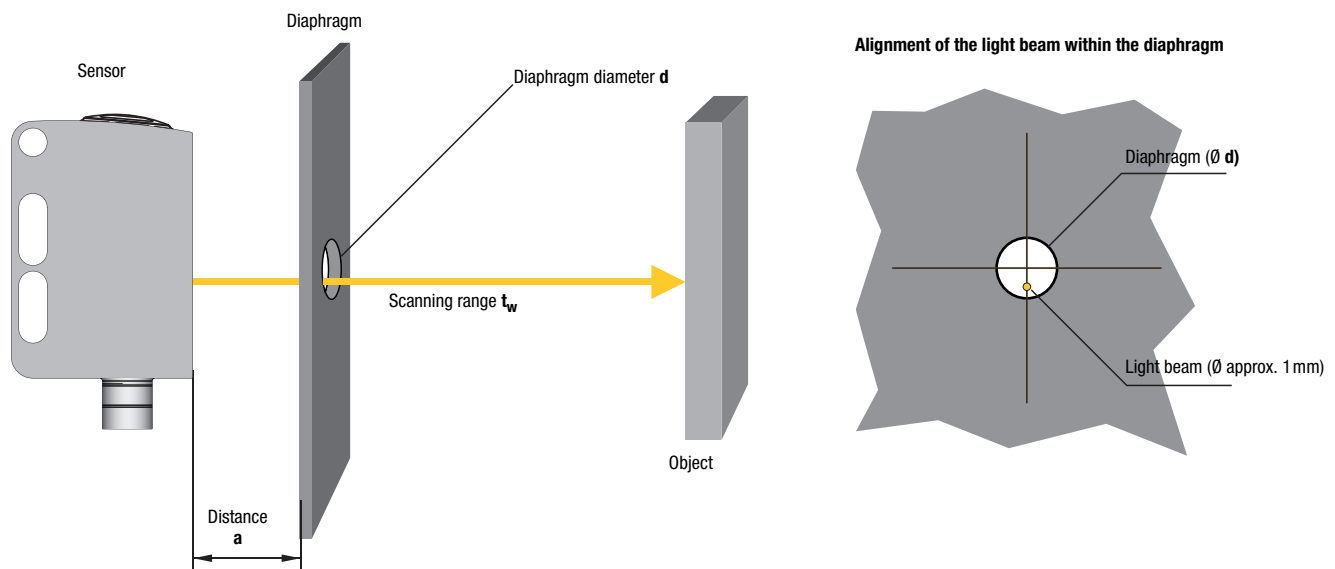

Detection of smallest objects

The laser scanner can also detect very thin parts (e.g., sheet metal plates or wire). Detection here depends, among other things, on set scanning range t_w , distance a to the object, and object size/thickness d .

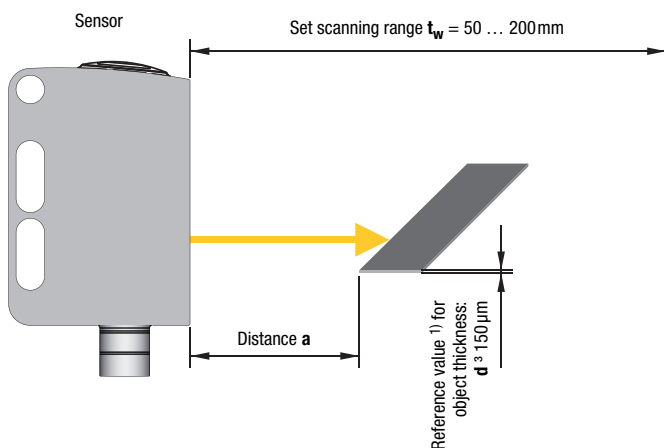

¹⁾  Reference values are not guaranteed properties. Due to the multitude of possible influencing factors, they must be confirmed in the application.

